

유비쿼터스 컴퓨팅을 위한
환경맥락 인식기술(Context-Awareness)의 소개

장세이, 우운택

GIST U-VR Lab.

<http://uvr.gist.ac.kr>



목 차

- 유비쿼터스 컴퓨팅 개요
 - 유비쿼터스 컴퓨팅과 지능화
 - 컨텍스트 및 컨텍스트 인식의 개념
- How to aware context?
 - 컨텍스트 획득을 위한 센서 및 센싱
 - 컨텍스트 모델링
- Context-based ubiComp application
 - 국내외 사례 연구



미래의 컴퓨팅 환경

■ 왜 유비쿼터스 컴퓨팅인가?

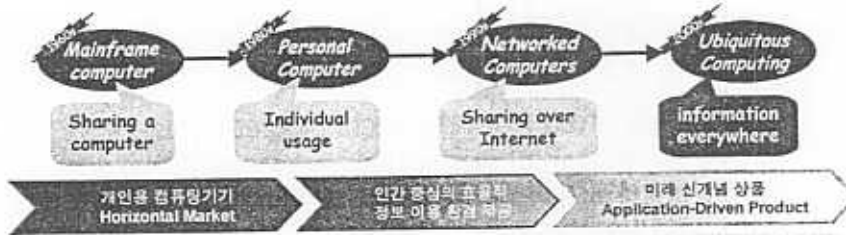

73: 8080/85
78: 8086/88
82: 80286
85: 80386
89: 80486

93: Pentium
95: P-pro
97: P-II
99: P-III
00: P-IV

The Major Trends in Computing



소형화, 지능화, 실감화



U-VR



미래의 컴퓨팅 환경

■ 유비쿼터스 컴퓨팅의 흐름

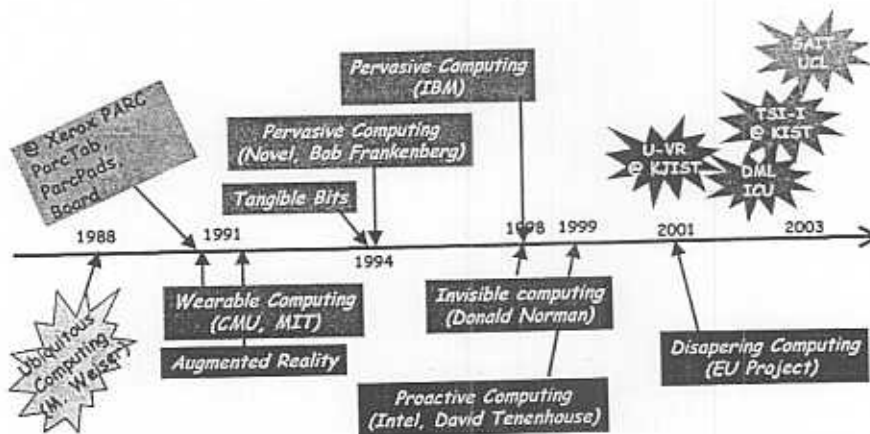

U-VR



유비쿼터스 컴퓨팅

- 유비쿼터스 컴퓨팅 vs. 네트워킹
- 유비쿼터스 컴퓨팅 enabling 기술의 정의
 - The focus is shifted from the technologies to users
 - 사람을 포함한 현실 공간에 존재하는 모든 대상물들을 기능적/공간적으로 연결해 사용자에게 필요한 정보나 서비스를 즉시 제공할 수 있는 기반 기술로 정의.

“The most profound technologies are those that disappear. They weave themselves into the fabric of everyday life until they are indistinguishable from it”

by Mark Weiser "The Computer for the 21st Century,"
Scientific American, vol.253, no.3, pp.94-104, Sep. 1991



유비쿼터스 컴퓨팅

- 사용자 중심의 ubiComp-enabling 기술 정의

“Any computing technology that allows human to do human-centered just-in-time interaction with environment via pervasive yet invisible interfaces” - GIST U-VR Lab
- 유비컴 기술의 특징 (Holistic)
 - 언제나 (Anytime), 어디서나 (Anywhere), 무엇이든지 (Anything) + ...: Network, device, data

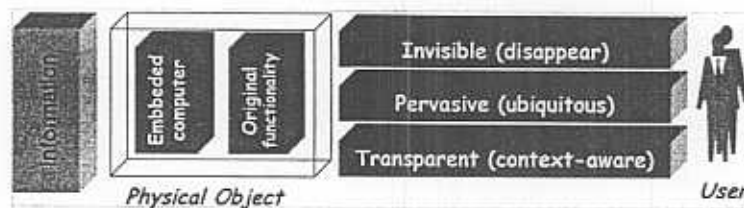

환경의 지능화

- 유비컴 관련 기술
 - Pervasive 인터페이스: 오감센서 및 센싱 기술
 - Pervasive sensing & Multi-modal interface
 - Personalized 에이전트: Context-aware 기술
 - **How to aware and represent Context: 5W1H**
 - Ubiquitous 네트워킹 및 미들웨어
 - How to represent & share context?
 - 응용 서비스
 - How to provide personalized service?

Motivation

- Communication btw Human and Human
- Communication btw Human and Computer
 - Modern computers are divorced from reality



스마트환경을 위한 디바이스의 지능화

- What's role of context?
 - Reduce explicit interaction, make more proactive
 - A *strategy* for building smarter devices & apps
- How to make devices smarter?
 - Let devices sense automatically, remember history, and adapt to changing situations

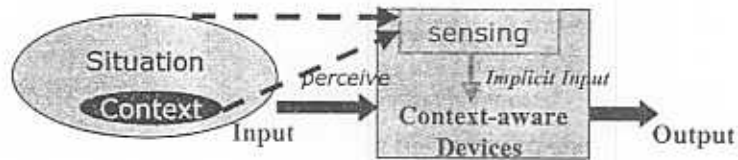

컨텍스트 정의

“Everybody has a different notion.”

- 사전적 정의: Context
 - “어떠한 것이 존재하거나 발생하는 밀접한 관계의 조건”
- Context in the literature:
 - location, identities of nearby people and objects.
 - time of day, season, temperature.
 - user's emotional state, focus of attention
 - environment the user and computer know about
 - state of the computer surroundings

컨텍스트 정의

"Everybody has a different notion."

▪ Schilit (1994)

- Computing 컨텍스트: 네트워크 연결도, 통신 비용, 대역, 근처 자원 (프린터, 디스플레이, PC, ...)
- 사용자 컨텍스트: 사용자의 profile, 위치, 근거리 사람들의 신분, 사회적 지위, 활동, ...
- 물리적 컨텍스트: 온도, 조명, 소음, 교통 상황 ...

▪ Dey & Abowd (2000)

- Context: 사람, 장소, 물리적 혹은 computational 객체의 상황을 특징화하는 데 사용되어질 수 있는 어떠한 종류의 정보
- Context-aware: if it uses context to provide relevant information and/or services to user, where relevancy depends on the user's task

컨텍스트 정의

"Everybody has a different notion."

▪ Woo & Jang (2002)

- 사용자 중심의 상황 기술 (a description of a user-centered situation)
 - Schilit의 정의에 덧붙여: 컨텍스트 *history* => 시간 컨텍스트
 - 아이디어를 결합하고 단순화 함: 5W1H

컨텍스트의 분류

▪ 분류 (Schmidt/Beigl/Gellersen, 2000):

▪ 사용자 요소 (Human Factors)

- 사용자 관련 정보: 습관, 감정상태, biophysical 상태
- 사용자의 사회적 환경: 관계, 사회적 상호작용, 그룹 활동
- 사용자의 일: 지속적인 활동, 직업적인 일, 일반적인 목표

▪ 물리적인 환경

- 위치: 절대/상대 위치
- 기반구조: Computation 및 communication을 위한 주변 자원
- 물리적 상태: 소음, 조명, 압력

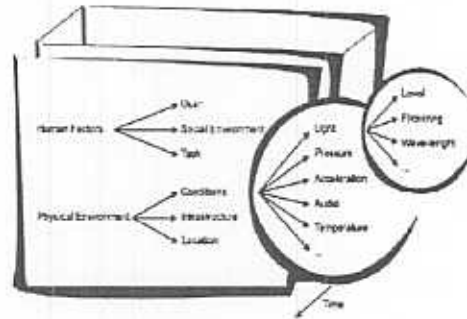

컨텍스트 인식 컴퓨팅

▪ Context-aware

- To recognize user's state and surroundings, and modify its behavior based on this info.

▪ Pascoe (1997)

- 사용 환경에 반응, 적응, 및 감지하는 장치 및 프로그램의 ability
- 컨텍스트-인식 특성 분류 (taxonomy of context-aware features)
 - Contextual 센싱: 어떻게 컨텍스트를 결정할 것인가?
 - Contextual 자원 발견
 - Contextual 증강: 데이터를 context와 어떻게 연관지을 것인가?

▪ Abowd (2000)

- 사용자에게 Task 관련한 정보 및/또는 서비스를 제공하기 위한 컨텍스트의 사용으로 정의

컨텍스트 인식 컴퓨팅

- 컨텍스트 인식의 목표
 - 기계와의 상호 작용이 쉽도록
 - 적절한 상황에 적절한 정보를 제공
- 컨텍스트 인식 컴퓨팅
 - 기존의 컴퓨터 형태가 아닌 (Breaking computers out of the box)
 - 컴퓨터가 내재된 물리적이고 사회적인 환경을 더욱 더 잘 인식할 수 있도록 하는 (Making computers more aware of the physical and social situations they are embedded in)
 - ubiComp 연구의 한 가닥 (One line of ubiquitous computing research)

컨텍스트 인식 컴퓨팅

- 컨텍스트 인식의 문제점
 - 사용성:
 - "A Context-aware Systems should make my life easier but if it makes mistakes I'm angry with it and the second time it does something wrong I turn it off (forgetting the many times it was working correctly...)"
 - 기술적인 논점:
 - 다수의 사람들이 기술 진행 정도에 관심을 둬:
 - They want cellular phones but we don't want the antennas...
 - 방대한 수의 센서 없이 어떻게 컨텍스트를 검색할 것인가?
 - 요구사항:
 - Client만이 정보결합을 할 수 있도록

컨텍스트 인식 컴퓨팅

- 컨텍스트 인식의 문제점
 - 확장성
 - Lots of people, places, things, and sensors
 - Over long periods of time
 - Over large geographic distances
 - Sharing resources (sensors and data)
 - 평가
 - 여전히 초기-중간 단계: 현재 초기 구현 상태
 - Target applications
 - 응급 반응 응용 시스템에 적합
 - 장애인의 통신을 위한 증강된 단어 예측
 - "Metrics"
 - 응용 시스템의 종류 및 효율성, 채택의 용이, 강건함

컨텍스트 인식 컴퓨팅

- 컨텍스트 인식의 문제점
 - Privacy
 - The more dependent on a pervasive computing, the more knowledgeable about user's moment
 - Tremendous source of valid criticism
 - 컴퓨터가 나에게 대해 뭘 알고 있나?
 - 누가 나의 현재 컨텍스트를 얻어 가는가?
 - I personally hate the idea that
 - Someone knows my location all the time
 - I still refuse to get a cell phone, but I may finally cave in!
 - 개인 정보를 보호하기 위해서 구조 및 메커니즘이 필요
 - 위치 기반 서비스는 사용자의 위치를 요구하지만, 사용자는 추적당하는 것을 원하지 않음
 - Need to establish mutual trust btw user and smart place
 - 편리함, 안정성, 효율성: What I gain vs. lose

목차

- Introduction to Context-aware
 - 유비쿼터스 컴퓨팅과 지능화
 - 컨텍스트 및 컨텍스트 인식의 개념
- How to aware context?
 - 컨텍스트 획득을 위한 센서 및 센싱
 - 컨텍스트 표현 및 모델링
- Context-based Applications
 - 국내외 사례 연구

컨텍스트 인식 컴퓨팅

- 컨텍스트 획득
 - Indirect context-aware:

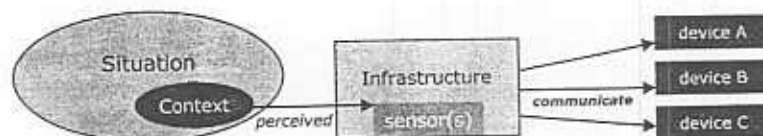

- Direct context-aware:

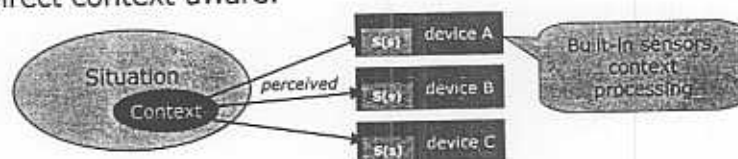

컨텍스트 인식 컴퓨팅

■ 컨텍스트의 획득

- 응용시스템 개발자는 제공하고자 하는 특성이나 행동들을 지원하기 위해 어떤 컨텍스트가 요구되어지는지 결정해야
- 왜 오늘날 컨텍스트 인식이 pervasive 하지 않는가? 왜 컨텍스트를 획득하는 것이 어려운가?
- 어떻게 보다 쉽게 생성된 컨텍스트 정보를 획득할 수 있을 것인가?
 - 개념이나 기반구조 없이, 응용 시스템은 컨텍스트 정보를 획득하기 위해서 기반 기술과 직접적으로 연결

■ 컨텍스트의 표현

- 5W1H: where, who, when, what, how, why

컨텍스트 인식 컴퓨팅

■ 센서(Sensor)

- 전기적/물리적/화학적 장치를 기반으로 환경 상태 및 변화를 감지하는 개체
 - attribute mixtures - often no one to one map
 - hidden state in environment
- A *transduction principle*
 - 다른 형태의 에너지로 변환 (conversion of energy from one form to another)



<IR/RF>



<weight sensor>

■ 센싱(Sensing)

- 사용자 및 주변환경에 대한 상황 정보를 감지하는 기능



<GPS>



<Bio sensor>

컨텍스트: Where

- 가장 보편화된 컨텍스트 정보
 - 표현방법
 - 좌표 위치, 공간 해상도
 - 활용 분야의 예
 - resource discovery(자원검색), "point-and-use" interfaces, navigation(탐사/운전), augmented reality(증강현실)
- 위치 기반 서비스의 필요 조건:
 - 정밀성 (accurate in space)
 - 정확성 (accurate in time)
 - 저렴성 (inexpensive)
 - 실내 및 실외 환경에서의 위치정보 연결성

컨텍스트: Where

- 실외환경
 - GPS (Global Positioning System)
 - 동작 원리
 - 위성에서 발산된 신호가 수신기로 전달될 때까지의 시간을 측정으로 발신기와 수신기의 거리 측정
 - 발신기 및 수신기의 동기화
 - 위치 추적을 위해서는 3개의 발신기의 신호를 감지할 때 3차원 좌표가 계산됨 (삼각측정)
 - 상업용 GPS의 정확성
 - 10-20 meters
- 실내환경
 - 적외선 신호 기반 위치 감지 시스템
 - (AT&T's Active Badge)
 - RF 신호 기반 위치 감지 시스템
 - 대체 가능 센서
 - magnetic, optical, acoustic
 - Scene analysis
 - 근접법(Proximity)
 - Contact, Beacon, Visual tags



컨텍스트: Where

▪ The Active Badge (92)

- 사용자 실내위치 및 상태 감지 시스템
 - Identity using an IR data link
 - Active maps: scalability

- @ Olivetti Research Lab (Cambridge, UK)



▪ ParcTabs (Schilit 95)

- Active badge+wireless: Rough location + ID

▪ Active Bat (Ward 97)

- Active Badge: only identify 2D location
- Ultrasonic fine-grained 3D location system



컨텍스트: Where

▪ Cricket (MIT Oxygen):

- An indoor location system for pervasive computing env.

▪ RADAR (Microsoft)

- A set of static receivers track positions of transmitters

▪ Barcode

- 1D vs. 2D & BW vs. color

▪ Load cell (GATECH) vs. ON/OFF cell (GIST)

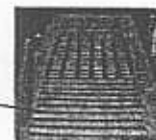

Simple ON/OFF switch

GIST



컨텍스트: Who

- Who: 사용자등과 같은 활동 주체에 대한 정보
 - 스마트 카드 (신용카드, 바코드, 등)
 - 생체 신호 기반 인식(Biometric sensors)
 - 지문, 홍채, 정맥 등
 - 얼굴 인식 (Face recognition): 카메라
 - 음성 인식 (Speech identification/recognition)

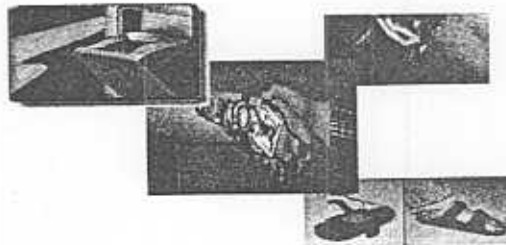

컨텍스트: Who

- Who: 사용자등과 같은 활동 주체에 대한 정보

Person="jasonh@cs.berkeley.edu"

Name="Location"
Value="Room 525"
Schema="Building:Room"
Metadata=
Time="1023498143"
Time-to-Live="60sec"
Source="SmartDust"

Name="Device"
Value=<http://zzz.com>
Schema="Device"

Attribute

Relationship

Entity

컨텍스트: What

- What: 사용자가 관심을 가지는 대상이나 동작
 - Body tracking
 - Gesture recognition
 - Activity recognition
 - Object recognition

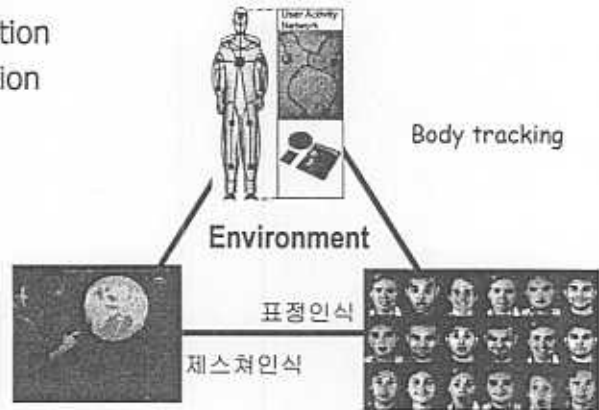

컨텍스트: How

- How & Why: 사용자의 의도 및 감정 정보
 - Sensing affect signals
 - Recognizing patterns of affective expression
 - 기쁨, 슬픔, 화남, 공포, 무서움, 억겨움 등



컨텍스트 인식 컴퓨팅

▪ 다중센서: Opportunities in UbiComp

- 여러 센서로부터 수집된 정보의 다양성
- 센싱된 정보의 공유를 위한 분산 처리 기술의 발전
- 정확성 높은 상황정보 판단 필요

▪ Fusion의 필요성

- One sensor is (usually) not enough
- 고성능 단일 센서의 문제점:
 - Sensors not 100% reliable
 - Noise, Limited Accuracy
 - Unreliable - Failure/redundancy
 - Limited point of view of the environment

- 해결 방법: Simple but cheap sensors (다중센서)

▪ Challenges

- 기존의 정보 통합 (information fusion) 기술을 컨텍스트 인식을 위한 분야로 어떻게 적용할 것인가?

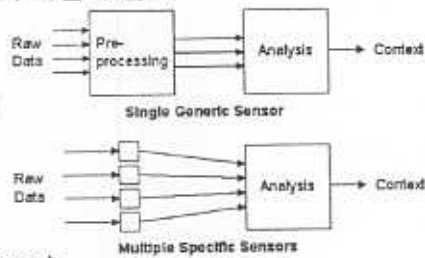

컨텍스트 모델링

▪ 컨텍스트 모델링의 핵심

▪ 객체 기반 접근 (Object-based approach):

- Entities: a physical or conceptual object
- Attributes: properties of entities
- Associations: linking an entity, its attributes & other entities
- Context description is a set of such assertions

▪ 문제점:

- 센서로부터 전달되는 raw sensor data를 응용서비스가 이용할 수 있는 high-level context로 변환의 어려움
- 센서 및 응용서비스의 종속성

▪ 해결책:

- 정보수집과 정보해석의 분리 (센서 및 응용서비스의 독립성)

컨텍스트 모델링

- 기반구조(Infrastructure)의 필요성
 - 공유 자원 (Share resources)
 - 데이터(data): Collaborative filtering, large data sets
 - processing power: Heavy-duty processing on dedicated machines
 - 센서: 환경의 센서 (Sensors in the environment)
 - 센서, 서비스, 및 응용 시스템의 독립적이고 동적인 변경
 - 새로운 알고리즘, 새로운 특징 (New algorithms, new features)
 - 이종 지원 (Supports heterogeneity)
 - 플랫폼, OS, 프로그래밍 언어, 장치 등에 독립적
 - 응용단 네트워크 프로토콜 및 데이터 형식에만 의존적인 서비스 상호 이용

컨텍스트 모델링

- 기반 구조를 위한 3가지 요구조건
 - 분산된 컨텍스트 센싱 네트워크
 - Interpretation 및 aggregation
 - 지속성 및 history
- 분산 컨텍스트-센싱 센서
 - 컨텍스트 서비스 상호 이용 및 이종 플랫폼 상의 응용
 - 설계 과정 (Design Process)
 - 사양 (Specification): 요구되는 컨텍스트 결정
 - 획득/전달/인지
 - 어떠한 하드웨어가 요구되어지는지
 - Action: 컨텍스트 인식의 선정 및 수행

컨텍스트 모델링

■ 기본 구조

- 각기 다른 일을 수행하는 레이어로 분리
- 표준화된 데이터 형식과 네트워크 프로토콜을 통한 레이어 간의 교차
- 서비스 셋을 제공하는 각 레이어
- 시스템 인터페이스가 변하지 않는 동안 레이어는 수정 및 변경 불가

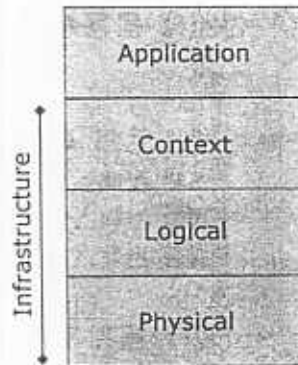

컨텍스트 모델링 Context Toolkit

■ Context Toolkit (Dey, Salber, Abowd 2001)

- 응용 서비스를 위한 컨텍스트 관리 도구 제안
 - 정보 수집, 컨텍스트 생성 및 관리 기능 (매개체)
 - 컨텍스트 생성 및 관리를 위한 기본 구성 요소의 역할 정의
- Three key abstractions
 - Widget: sensor independent presentation of context
 - Interpreter: interprets context
 - Aggregator: represents summary on several widgets

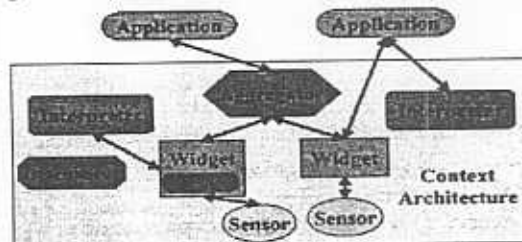

컨텍스트 모델링: ubi-UCAM

■ Ubi-UCAM (Jang & Woo 2003)

- 단일화된 컨텍스트를 이용한 센서와 응용서비스의 독립성 보장
- 컨텍스트의 세분화
 - 초벌 컨텍스트
 - 통합 컨텍스트
 - 최종 컨텍스트
- 단일 사용자 중심의 ubi-Home 응용

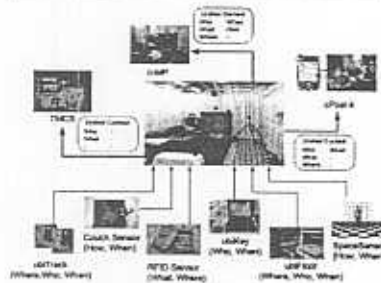
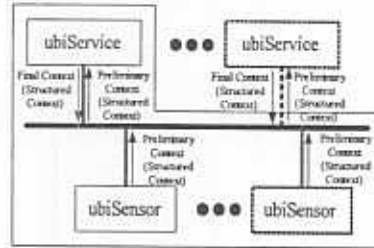

Ubi-UCAM을 기반으로 개발된 센서 및 응용 서비스의 구현 예



컨텍스트 모델링: ubi-UCAM 2.0

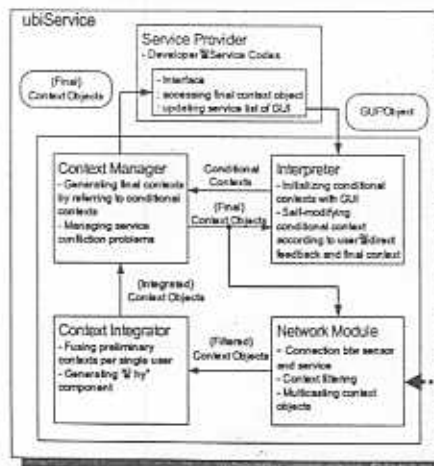

• 컨텍스트 포매팅 (Context Object)

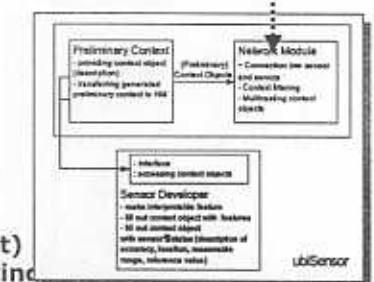
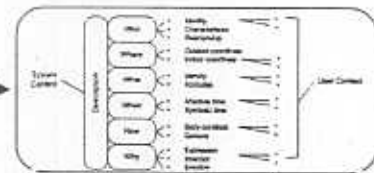

- 다중사용자 지원 (multi-user support)
- 서비스 충돌 해결 (Conflict resolving)
- 지능화된 개인 서비스 환경 (Personalized services w/o scenarios)



Context Integration

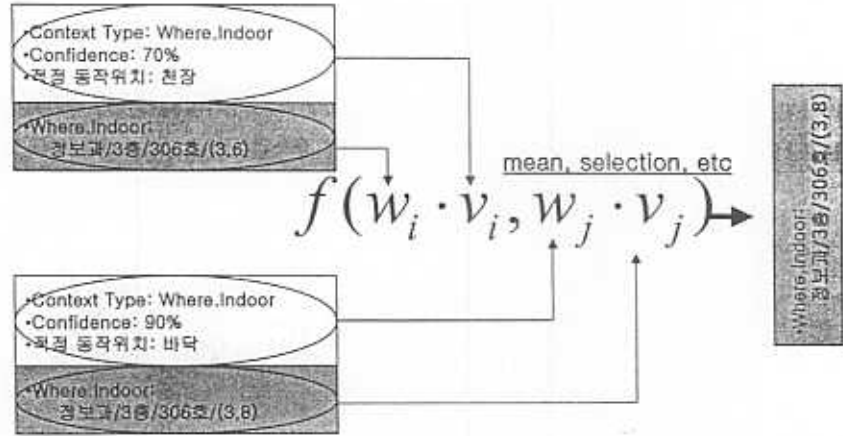

Context Management

사용자 충돌

- 하나의 서비스를 실행시키는 두 사람 이상의 컨텍스트 조건 동시 발생



서비스 충돌

- 서로 상반되는 특징을 나타내는 서비스들이 동시에 실행 때

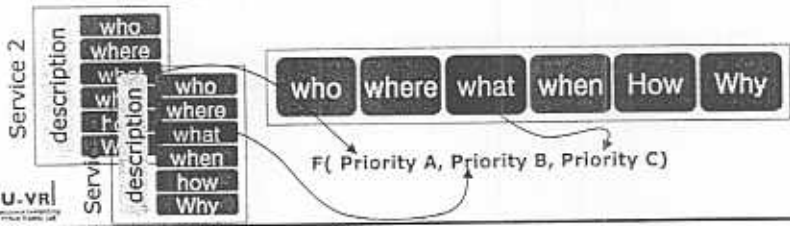

지능화된 개인 서비스 환경

Self-modifying Conditional Context

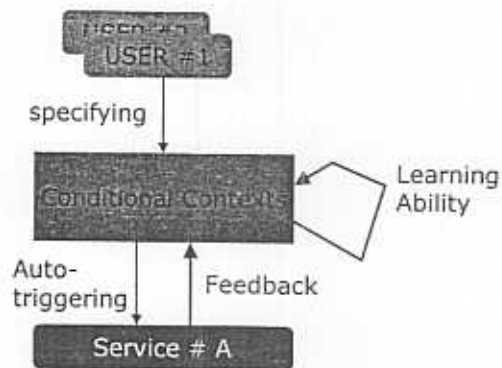

컨텍스트 모델링: ubi-UCAM

Main Contributions

- ubiComp 환경을 위한 컨텍스트 기반 시스템을 위한 모델
 - 센서와 응용서비스의 동적 연결성
 - 컨텍스트의 재사용성 (reusability)
 - 단일화된 표현: 5W1H(Who,What,Where,When,Why,How)
- 서비스 개발자와 사용자를 모두 고려한 디자인

Context Toolkit vs. ubi-UCAM

Features	Context Toolkit	ubi-UCAM
센서와 서비스의 독립성	O (Widget)	O (unified context)
컨텍스트의 표현성	O (Developer's definition)	5W1H
컨텍스트의 통합	X (widget)	O (Context Integrater)
컨텍스트 기반 서비스들간 상호 연결성	X	O
적용 대상	Current Computing Env.	UbiComp Env.

응용서비스: Home

- Obstacles: People...
 - Believe that computer make life more complex



U-VR
U-VR
U-VR



응용서비스: Office

- Obstacles: People...
 - Believe that computer make life more complex



U-VR
U-VR
U-VR



응용서비스: Car

Why Smart Car?

- Power/energy,
- Cost,
- UI, size/weight,
- Tracking, etc.

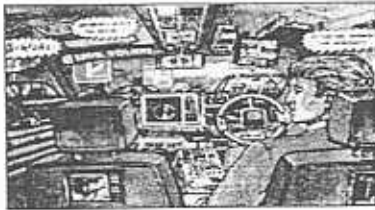

U-VR
UNIVERSITY OF VIRGINIA
RESEARCH CENTER



응용서비스: etc.



Military



eclass@GATECH



Hospital



Tourist

U-VR
UNIVERSITY OF VIRGINIA
RESEARCH CENTER



국내외 관련 연구 동향

- ubiComp-related Research activities
 - TTT (1995-, MIT Media Lab.)
 - Smart Dust (1998-, UCB)
 - Oxygen (1999-, MIT AI Lab.)
 - Endeavour (1999-, UCB)
 - Aura (1999-, CS, CMU)
 - Portolano (UW)
 - HP cooltown (2000-, HP)
 - TecO (1993-)
 - In Korea
 - Digital Life (Samsung), iHome (LG), smarHome (ETRI)
 - Smart Home (ICU), Tangible Initiative (KIST), etc.

R&D in GIST U-VR Lab

- wearComp, ubiComp & VR

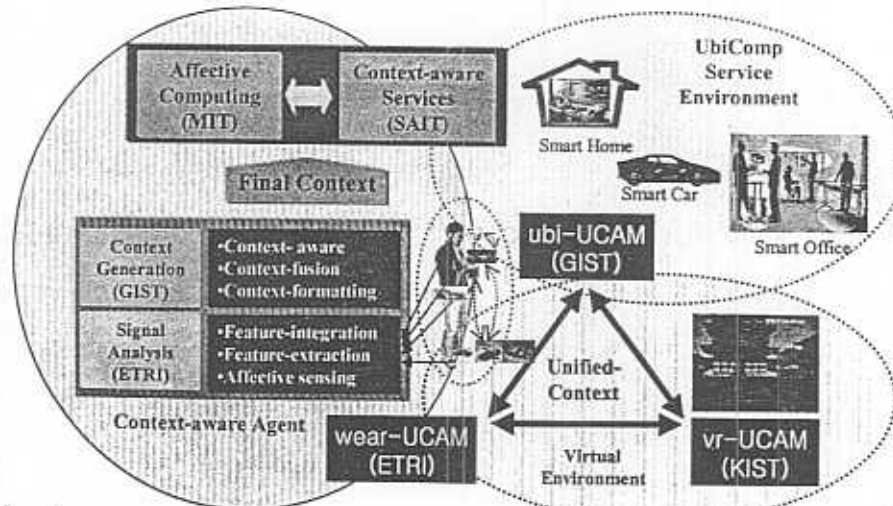

컨택스트 기반 응용 서비스(GIST)

- Pervasive Sensing Technology
- Context-awareness Technology
- Intelligent Service Development

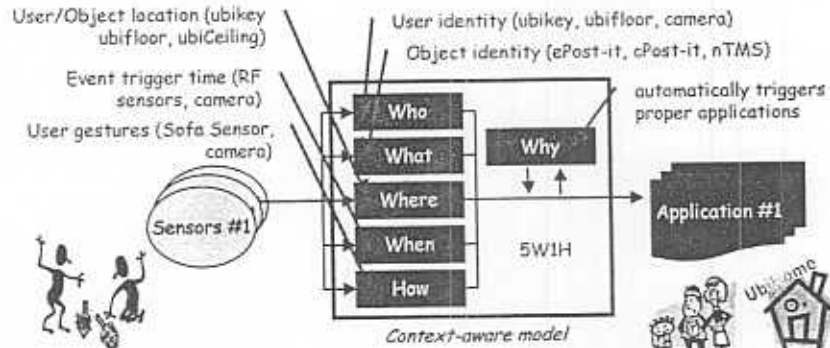

U-VR



GIST ubiHome (2001-)

- ubi-UCAM (IITA,01-03)
 - Unified Context-Aware Application Model
 - ubiSensor & ubiService

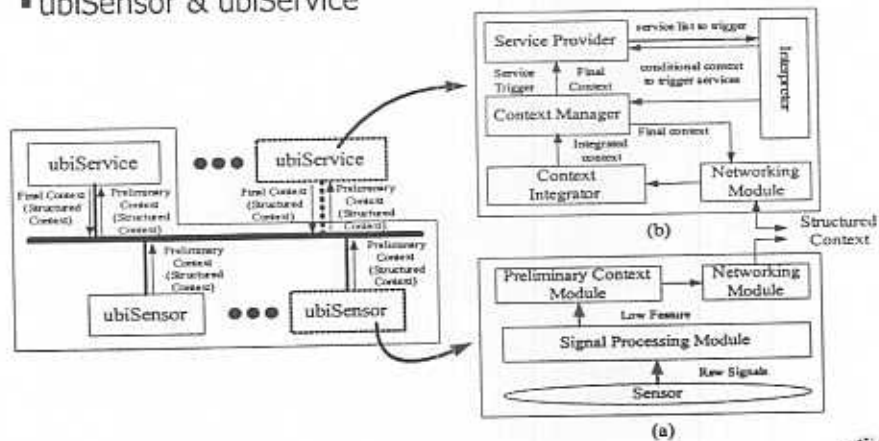

U-VR



Smart Home

▪ ubiHome-related Projects

- Easy Living (MS Research, since 1998)
 - Self-aware space, casual access to computing
- Aware Home (GATECH, since 1999)
 - UbiComp application for aging people
- Adaptive House (Colorado Univ., since 1999)
 - Prediction (neural net, fuzzy theory)
 - Residential comfort systems
- House_n Project (MIT, since 2000)
 - Interactive UI, Adaptable, customized environment
 - Now "changing place"
- UbiHome (KJIST, since 2001)
 - Context-based human-centered services
 - Ubi-UCAM with ubiSensor & ubiServices
- DML (ICU DML, since 2002)

ubiHome @ GIST

▪ Services in ubiHome (Demo Video)

- 20-30's Family (including infant)
- Context-based Personalized Service

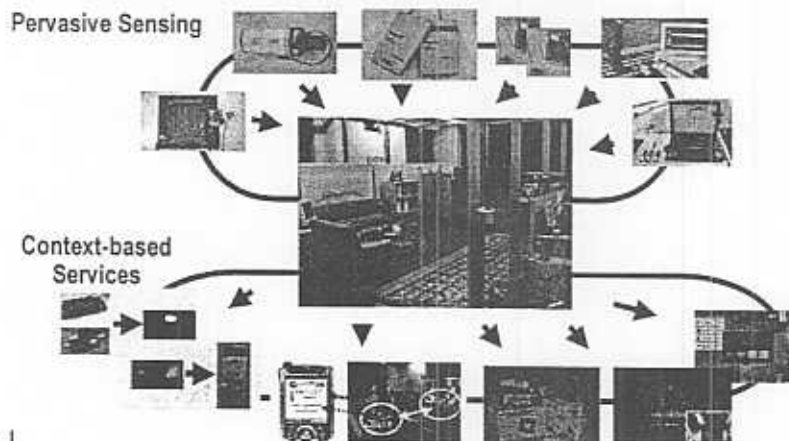

ubiHome @ GIST: Sensing

- Sensing in ubiHome
 - Sensing user & environment nearby the user
 - The variety of Sensors

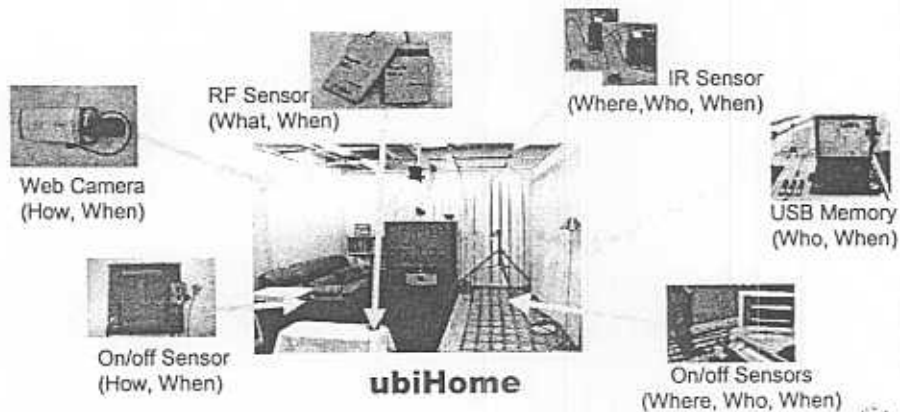

ubiHome @ GIST

- ubiKey (IITA,01-03)
 - user's id (who)
 - user's profile (when, what)

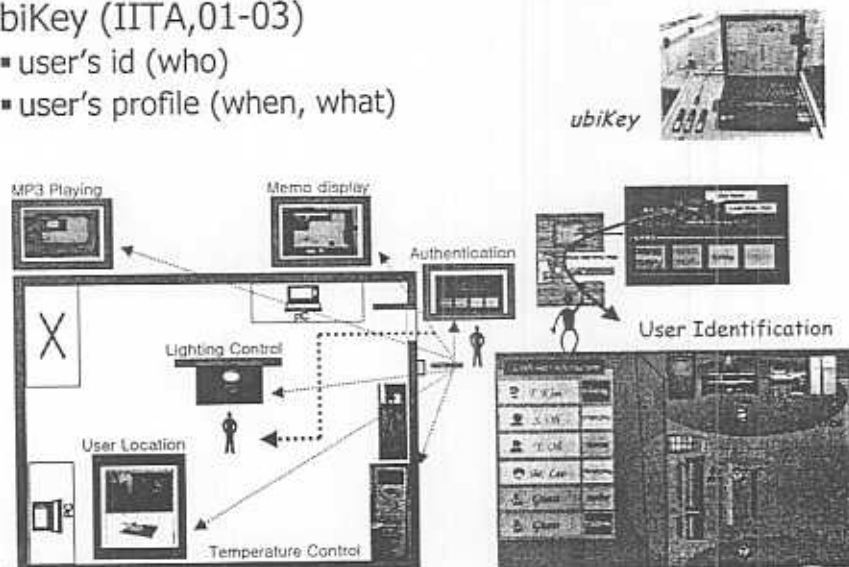

ubiHome @ GIST

▪ SpaceSensor (KIST,01-02)

- Gesture (what, how)

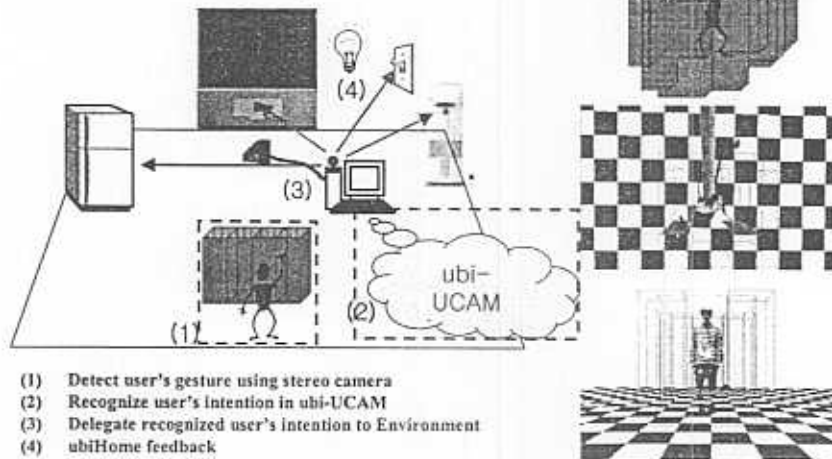

- (1) Detect user's gesture using stereo camera
- (2) Recognize user's intention in ubi-UCAM
- (3) Delegate recognized user's intention to Environment
- (4) ubiHome feedback

U-VRI

GIST

ubiHome @ GIST

▪ ubiFloor (IITA,01-03)

- Location-aware (where, when)
- User identification (who)
 - Walking pattern, velocity, acceleration, etc.
 - Free from noise & lighting condition

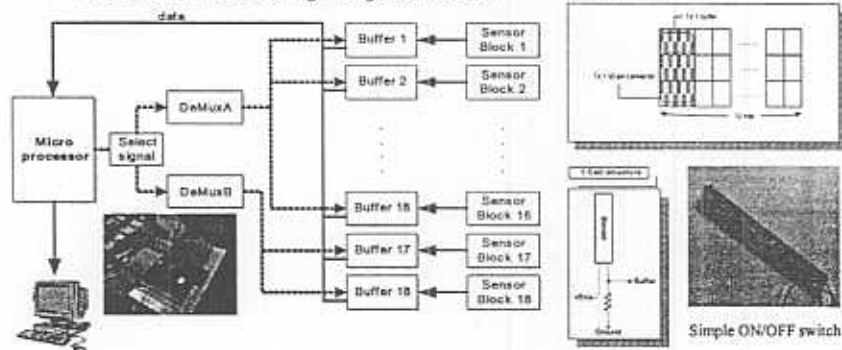

U-VRI

GIST

ubiHome @ GIST

- Dance Floor(KJIST, 01-02)
 - Application of ubiFloor
 - Play FG/BG music based on step pattern & speed

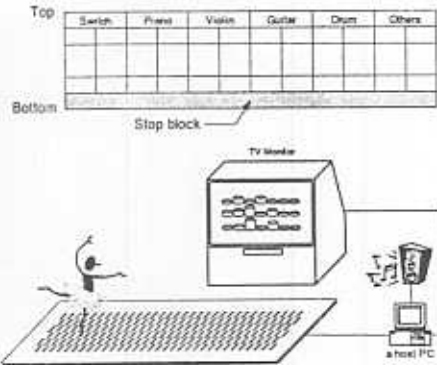
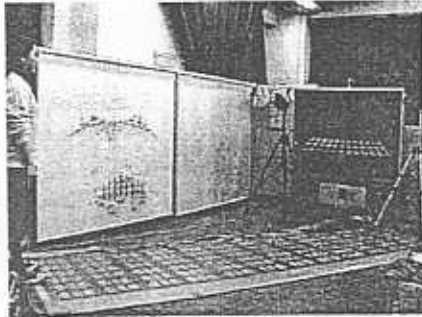

U-VR

ubiHome @ GIST

- ubiCeiling (SAIT, 02-03)
 - User's Location-aware & identification
 - IR sensing -> User/Object Info. from PDA or DB

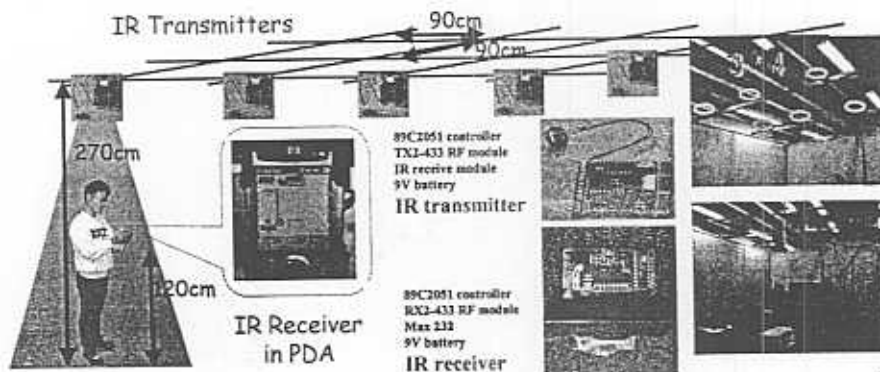

U-VR

ubiHome @ GIST

- ubiSensor (IITA,01-03)
 - User-centered Pervasive Interface

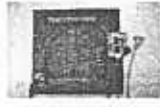

Sofa Sensor

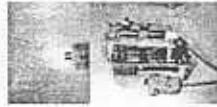

IR Sensor



Web Camera



Selection User Dialog



Movie Service Dialog



Selection User Dialog on PDA



Movie Service Dialog on PDA



ubiHome @ GIST

- Intelligent Service (ubiService)
 - Context-based Service
 - 20-30's Family (including infant)
 - Personalized Service

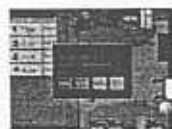

ubiKey

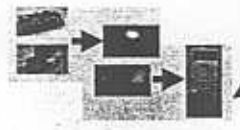

Home Controller



cPost-it



n-TMP



c-MP



ubiHome @ GIST

- cMP: (IITA, 02-03)
 - context-based Media Player

id	name	location	status
1	user	100-100-100-100	on
2	movie	100-100-100-100	on
3	time	100-100-100-100	on
4	state	100-100-100-100	on
5	location	100-100-100-100	on
6	status	100-100-100-100	on

Context-based Service: user name, movie title, time control, state



Camera display triggering in the middle of movie playing

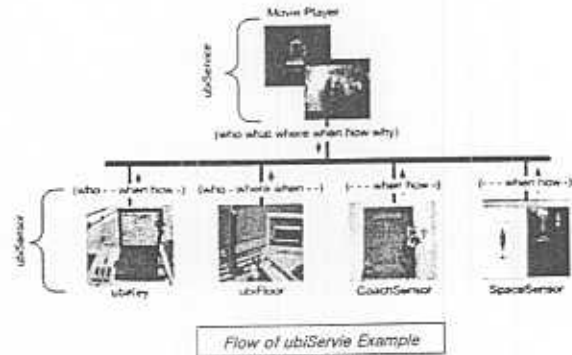

ubiHome @ GIST

- nTMS: (IITA, 01-03)
 - Nomadic Tangible Media System
 - RF transponder: "http address" or "control"
 - Retrieves media data (e.g. postcard, CD case, etc.)
 - Control using tangible object with RF tag

Control Object



Media Object

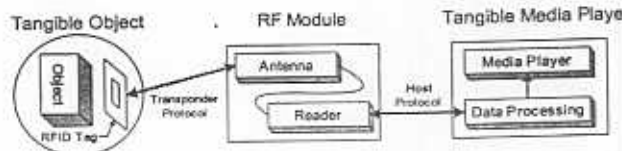

ubiHome @ GIST

▪ CESUE (DML,02-03)

- Cooking Education System for ubiHome Env.



System Configuration

▪ ARKB (GIST,02-03)

- Augmented Keyboard for 3D HMD



ubiHome @ GIST

▪ cPost-it 구현



ubiHome

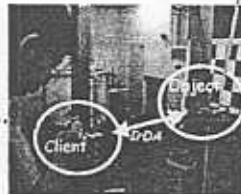

ubiHome @ GIST

▪ aPost-it Architecture (SAIT 2004)

- Flexible information augmentation
- Context-based information sharing (5W1H)
- Personalized augmentation

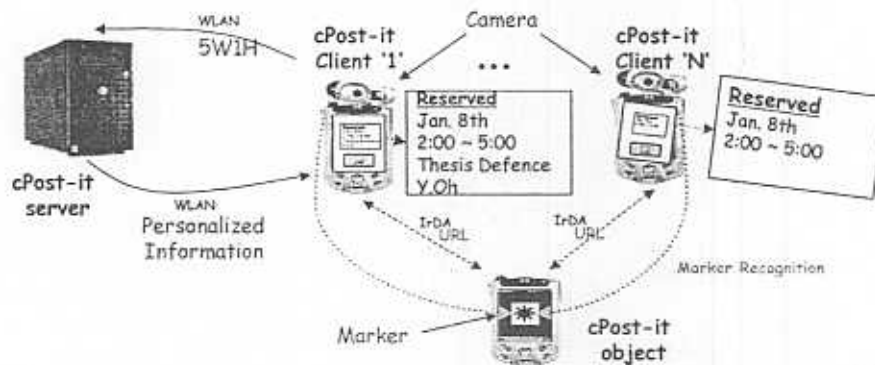

U-VRI

GIST

ubiHome @ GIST: How it works?

▪ ubi-UCAM 2.0

- Unified Context-aware Application Model (5W1H)
- ubiSensor & ubiService

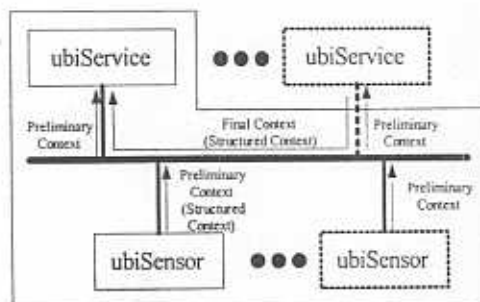

Structured Context

- **Preliminary Context**
Not be accurate or incomplete info (sensor)
- **Integrated Context**
Merged the preliminary contexts (application)
- **Final Context**
Refined integrated context to trigger a service (application)

U-VRI

GIST

ubiHome 2004 @ GIST

- Integrated ubiHome
 - Conflicition in ubiHome Testbed
 - Scenario-based Killer Application

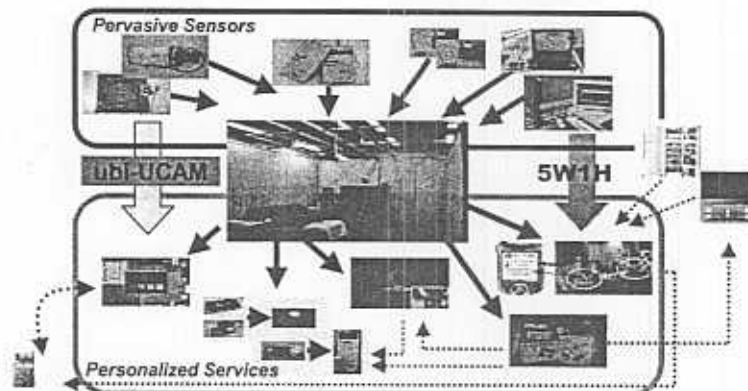

U-VR



ubiHome 2004 @ GIST

- uPost-it (2004)

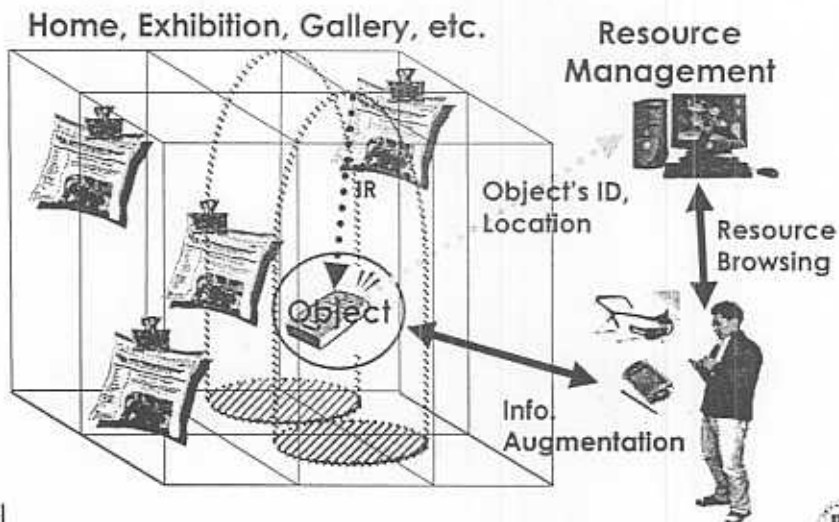

U-VR



- 컨텍스트 인식 개요
 - 유비쿼터스 컴퓨팅과 지능화
 - 컨텍스트 및 컨텍스트 인식의 개념

How to aware context?

- 컨텍스트 획득을 위한 센서 및 센싱
- 컨텍스트 모델링

Context-based ubiComp application

- 국내외 사례 연구



Q & A

- Discussions & More information

장세이, Ph.D. Candidate

광주과학기술원 U-VR 연구실
 Gwangju 500-712, S. Korea
 T. +82-62-970-3157

mailto:jangsei@gist.ac.kr
 Web: <http://uvr.gist.ac.kr>



Thank You!



References

- Anind K. Dey, "Providing Architectural Support for Building Context Aware Applications," PhD thesis, GATECH, Nov. 2000.
- Bill N. Schilit, "A System Architecture for Context Aware Mobile Computing," PhD thesis, Columbia University, New York, NY, US, 1995.
- Thomas P. Moran, "Human Computer Interaction," A Journal of Theoretical, Empirical, and Methodological Issues of User Science and of System Design, vol. 16, 2001.
- "Special Issue on Context Aware Computing," Springer Verlag, Personal and Ubiquitous Computing, vol. 5, 2001.
- S. Jang, W. Woo, "ubi-UCAM: A Unified Context-Aware Application Model," LNAI/LNCS (Context03), pp. 178-189, 2003.
- S.Jang, S.Lee, W. Woo, "cPost-it: Context-based Information Sharing System," LNCS (MIPS03), vol.2899, pp. 352-363, 2003.